

S-96MW SERIES

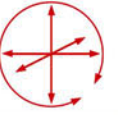

4-Axis RF/Microwave Micropositioner

The S-96MW has been specifically engineered for the unique demands of high-frequency testing, rather than just modified from an existing DC design. Extended length ball & race bearings, captive leadscrews, and increased mass insure non-resonant performance to W-Band and beyond.

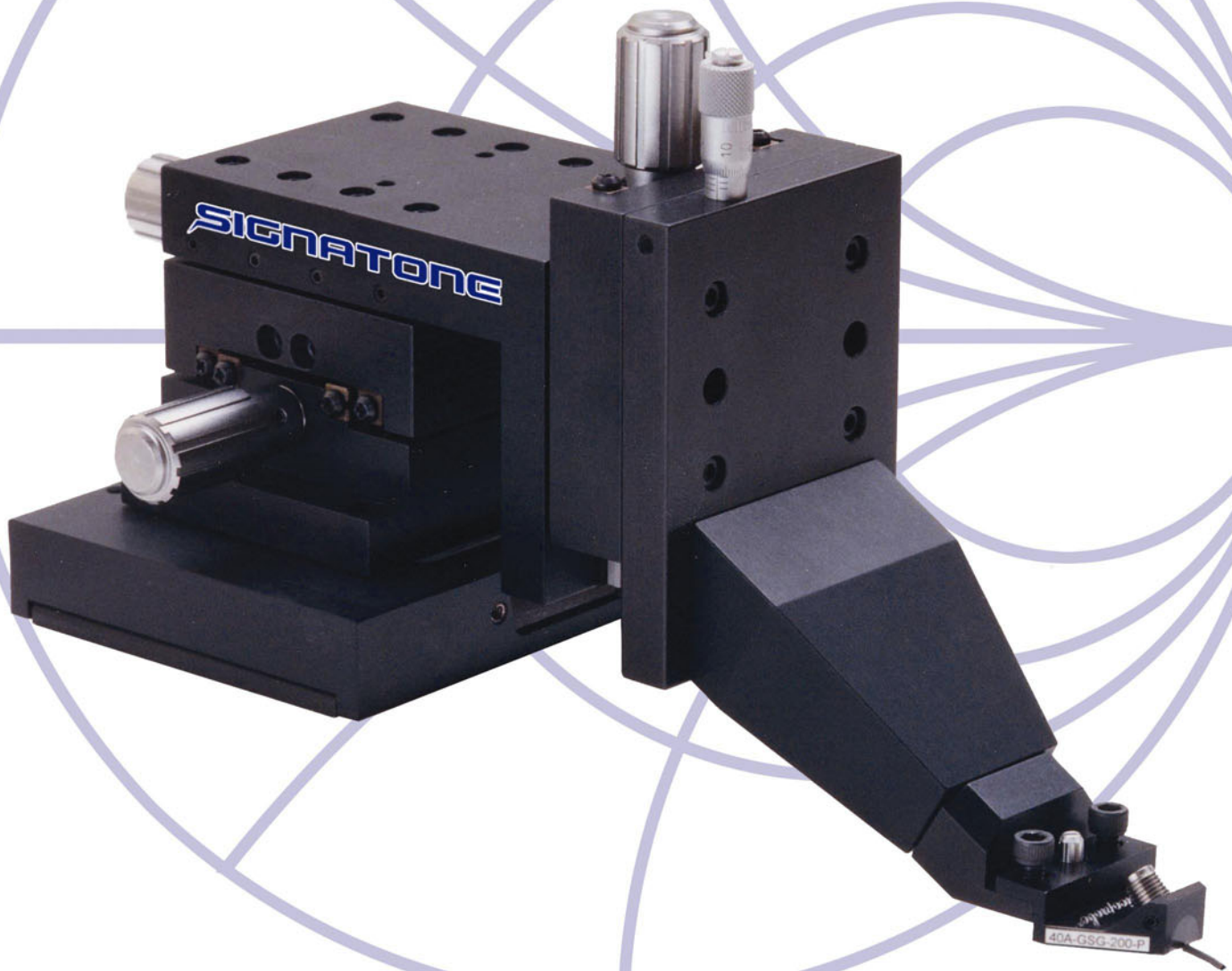

PERFORMANCE, QUALITY, VALUE

SIGNATONE®

Advanced Microprobing Solutions Since 1968

S-96MW SERIES



Specifications

S-96MW	
Travel Range X,Y&Z	1"
Planarization Rotation	10°
Resolution	5μ
Orientation	N, S, E, W
Standard: MM	Magnetic Base
Optional: VM	Vacuum Base
HM	Bolt-Down Base

Standard S-96MW

1" of X-Y-Z Travel @ 40 TPI

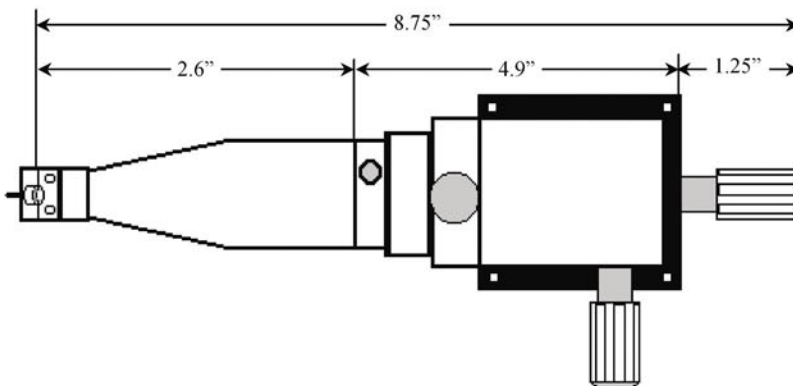
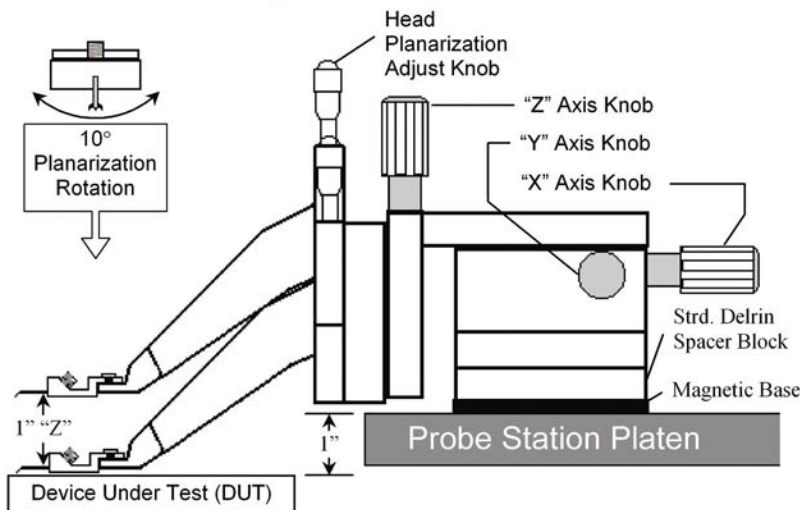

The SIGNATONE Model S-96MW features 25mm of X-Y and Z translation. A planarization adjustment assures planer contact of the GSG/GS/SG probe. The stiff micropositioner body assures near-zero backlash when moving the probe, even when using rigid or semirigid signal cables. The S-96MW is available with magnetic, vacuum, or bolt-down bases.

North, South, East & West options permit up to 4 probes or wedges to be used simultaneously. The positioner supports both GGB and Cascade probe heads.

Orientation

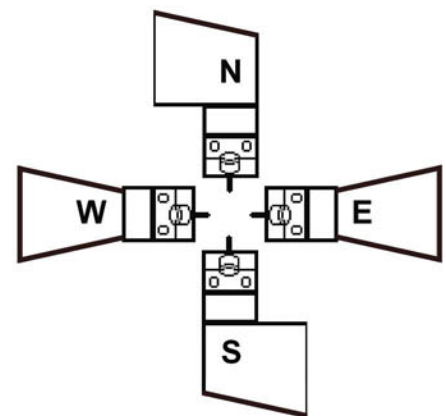

SIGNATONE

393-J Tomkins Court, Gilroy CA 95020

Phone: 408-848-2851 Fax: 408-848-5763

E-Mail: sales@signatone.com WWW: <http://www.signatone.com>

Picoprobe®

BY GGB INDUSTRIES INC.

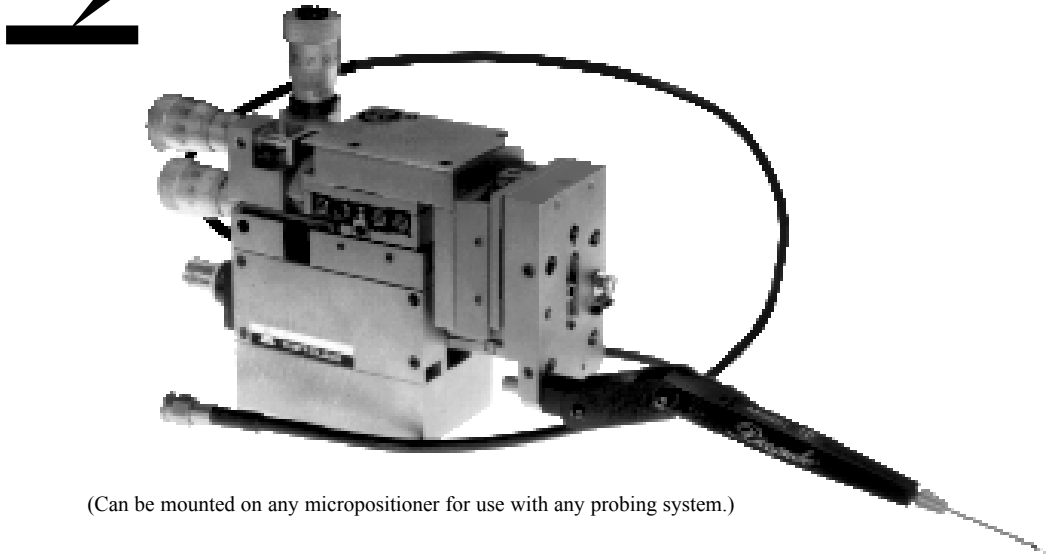

(Can be mounted on any micropositioner for use with any probing system.)

Picoprobe® Model 10 is a multipurpose, high speed, passive probe which can be used for driving as well as receiving signals. The Model 10 consists of a one meter length of flexible 50 Ω coaxial cable terminated by a carefully trimmed SMA connector on one end and by a miniature, high speed 50 Ω connector specially developed to receive Model 10 replaceable coaxial probe tips on the other. The 50 Ω coaxial cable was custom designed for the Model 10 to accommodate high speed signals, yet remain very flexible, so that moving the cable would not disturb the probe points.

Adaptable for a wide range of applications, the Model 10 uses a variety of special purpose, easily replaceable probe tips. Each probe tip consists of a 1.5 inch long 50 Ω semi-rigid coaxial line, a retaining nut, one or two probe points, and a variety of electrical components tailored to achieve the desired performance characteristics.

To drive or receive signals on 50 Ω circuit points, we recommend the Picoprobe® Model 10 be fitted with a probe tip that has two probe points, one for the ground and one for the signal. Probe points which extend 0.120 inches beyond the 50 Ω coaxial probe tip have been designed for dc to 3.5 GHz response and probe points which extend 0.030 inches beyond the probe tip have been designed for dc to 7 GHz response. The longer 0.120 inch tips are more flexible, making them more durable and easier to use than the shorter 0.030 inch style. To receive signals from high impedance circuit points, Model 10 probe tips with a 250 Ω, 500 Ω, or 5 k Ω input resistance should be used. The 250 Ω tip should be used with 0.180 inch long dual probe points to achieve dc to 10 GHz response. The signal will be attenuated by 5:1. The 500 Ω tip should be used either with 0.180 inch long dual probe points to achieve dc to 11 GHz response or with a 2 inch long ground strap to achieve dc to 4 GHz response. The signal will be attenuated by 10:1. The 5k Ω tip should be used either with 0.180 inch long dual probe points to achieve dc to 5 GHz response, a 2 inch ground strap to achieve dc to 4 GHz response, or a 6 inch ground strap to achieve dc to 2 GHz response. The signal will be attenuated by 100:1. To drive high impedance circuit points, Model 10 probe tips with a 50Ω terminating resistor should be used. See chart below.

All Model 10 probe tips manufactured by GGB Industries, Inc. have been trimmed to compensate for cable loss and minimize the need for a short ground. Grounding methods would depend upon the desired frequency response and range from dual probe points to a 6 inch long flexible ground strap. In applications where many circuit points must be accessed and a ground is not conveniently located, a flexible ground strap can be substituted for the ground point.

<p>50 Ω Input Impedance Mode</p> <table border="0"> <tr> <td></td> <td>0.120"</td> <td>0.030"</td> </tr> <tr> <td>frequency response -</td> <td>dc to 3.5 GHz</td> <td>dc to 7 GHz</td> </tr> <tr> <td>insertion loss -</td> <td>3dB</td> <td>3db</td> </tr> <tr> <td>return loss -</td> <td>>10 dB</td> <td>>10 dB</td> </tr> <tr> <td>attenuation -</td> <td>1:1</td> <td>1:1</td> </tr> </table>		0.120"	0.030"	frequency response -	dc to 3.5 GHz	dc to 7 GHz	insertion loss -	3dB	3db	return loss -	>10 dB	>10 dB	attenuation -	1:1	1:1	<p>250 Ω Input Impedance Mode</p> <p>frequency response - dc to 10 GHz (-3 dB) attenuation - 5:1</p>
	0.120"	0.030"														
frequency response -	dc to 3.5 GHz	dc to 7 GHz														
insertion loss -	3dB	3db														
return loss -	>10 dB	>10 dB														
attenuation -	1:1	1:1														
<p>500 Ω Input Impedance Mode</p> <p>frequency response - dc to 11 GHz (-3 dB) attenuation - 10:1</p>	<p>5 KΩ Input Impedance Mode</p> <p>frequency response - dc to 5 GHz (+3 dB) attenuation - 100:1</p>															

Model 10 Picoprobe® Replacement Tips Part Number System

Model 10 tip part numbers can be determined by filling in the spaces above each column in this chart.

10						
Model Number	Added Resistance to 50 Ω Coaxial Tip	Outside diameter of probing wire	Probing wire material	No. of probing wires	Ground R / L	Space Between Points
	50/30 = No added resistance (50 Ω coax to 0.030" long probe tips) 50/120 = No added resistance (50 Ω coax to 0.120" long probe tips) 50T = 50 Ω resistor placed between center conductor and shield just before probe tips. 50C = a capacitor placed between center conductor and shield just before probe tips. (specify value) 250 = 250 Ω input resistance attenuates 5:1 500 = 500 Ω input resistance attenuates 10:1 1K = 1000 Ω input resistance attenuates 20:1 2.5K = 2500 Ω input resistance attenuates 50:1 5K = 5000 Ω input resistance attenuates 100:1	125 = 125 micron wire sharpened to approx. 5 microns for tungsten and 25 microns for Pd or BeCu 60 = 60 micron wire sharpened to approx. 3 microns for tungsten and 10 microns for Pd or BeCu 35 = 35 micron wire sharpened to approx. 2microns (tungsten only) 22 = 22 micron wire sharpened to approx. 1 micron (tungsten only) 10 = 10 micron wire sharpened to approx. 0.2 micron (tungsten only)	W = Tungsten Pd = Palladium BeCu = Beryllium Copper	1 = one signal wire only 2 = one signal wire and one ground wire Note: If "1" is entered end part number here	R= Right L= Left Ground on Right or Left side of signal point as seen looking from front to back of Model 10	Spacing between signal and ground points (indicate distance in either inches or microns)

Example: 10-500-60-W-2-R-120 micron - Denotes a Model 10 probe tip with 500 Ω input resistance, 60 micron probing wires, one signal and one ground wire made of tungsten, the ground is on the right side of the signal wire, and the space between probe points is 120 microns.

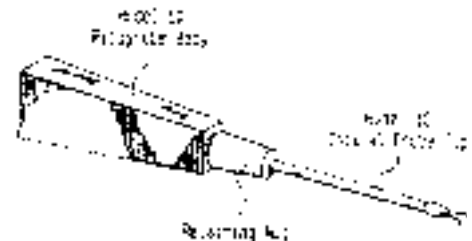
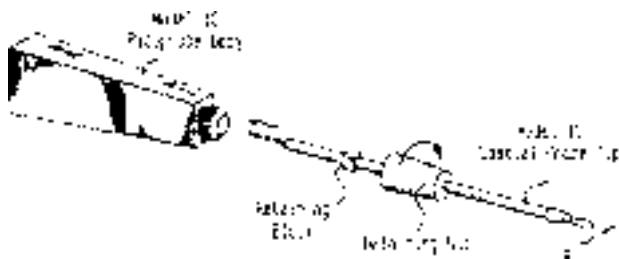

Picoprobe®

BY GGB INDUSTRIES INC.

Model 40A

High Performance Microwave Probes

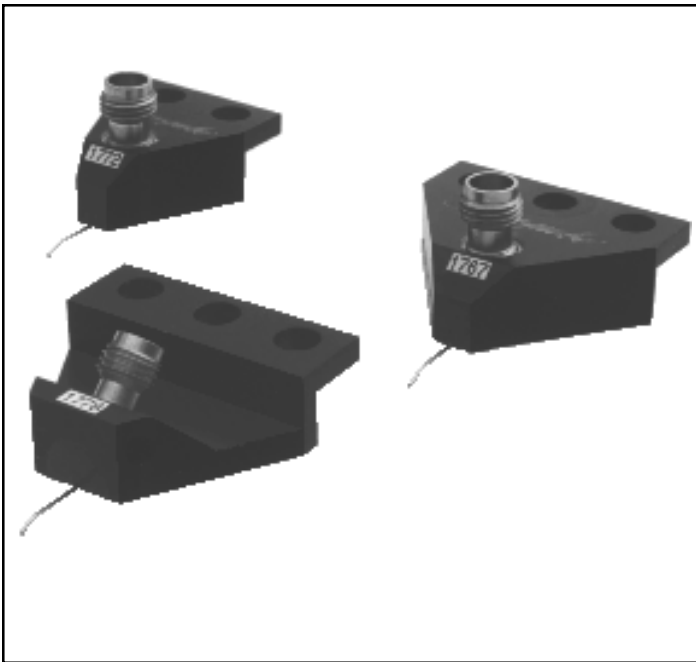

Model 40A probes mounted in three different adaptor styles

The GGB Industries, Inc., Model 40A Picoprobe® sets new standards in microwave probing performance. Using low loss coaxial techniques, the Model 40A achieves an insertion loss of less than 0.8 db and a return loss of greater than 18 db through 40 GHz.

With its individually spring loaded Beryllium-Copper or optional Tungsten tips, the Model 40A provides reliable contacts, even when probing non-planar

structures. This reliable low resistance contact is one of the keys to providing highly repeatable measurements. The Model 40A also provides direct viewing of the probe tips for accurate positioning.

The Model 40A can be mounted in various adaptors for use with standard microwave probe stations or attached to thin blades for use with dc probe needles on a probe card or multi-contact wedge. Custom mounts are available.

Features

- **Durable**
- **DC to 40 GHz**
- **Insertion loss less than 0.8 db**
- **Return loss greater than 18 db**
- **Measurement repeatability -80 db**
- **Individually spring loaded contacts**
- **BeCu or Tungsten tips available**
- **Any pitch from 50 to 1250 microns**
- **Variety of Footprints**
- **Patented coaxial design**

Any pitch (tip spacing) from 50 to 1250 microns may be specified. Probe pitches greater than 1250 microns can be accommodated. The probe can be configured with Ground-Signal-Ground (G,S,G), Ground-Signal (G,S), or Signal-Ground (S,G) tip footprints. We recommend smaller pitches with a G,S,G footprint for best performance.

Connection to the Model 40A is through a female K connector and is compatible with the 3.5 mm and SMA connectors.

Flexible Tips for Flexible Probing

Each Model 40A has patented, independently spring loaded tips which ensure a reliable contact to the probing surface. Because the tips are flexible they minimize circuit damage, increase probe life, and most importantly, provide a reliable individually spring loaded contact for each point. With a small amount of overdrive, the point scrubs the surface to make a reliable contact free of dust, dirt, and oxide contamination. The ability to view the exact contact area eases probe positioning and allows for the precise positioning necessary for good LRM calibrations. The flexible tips even allow probing of non-planar surfaces such as ceramic substrates and laser diode structures.

Coaxial Transmission Improves Performance

The Model 40A uses a precision miniature 50 ohm coaxial cable from the probe tips to the connector interface. The coaxial design provides lower loss and less radiation than coplanar designs. The miniature coaxial cable is fabricated from flexible Beryllium-Copper which greatly improves the probe's durability.

Probe Cards & Multi-Contact Wedges

Model 40A probes can be mounted on standard 4.5 inch probe cards, custom-sized cards, and our unique multi-contact wedge bodies to provide a convenient method for testing wafers at high frequencies using standard automatic or manual probe stations. Picoprobe Cards and Multi-Contact Wedges can be designed with 40, 50, 67, and/or 110 GHz probes for RF connections with DC needles for power and low frequency signals.

An Entire Line of Microwave Probes

For special applications, the Model 40A can be mounted in custom adaptors, the coaxial line can be bent to fit tight spaces, and the tips can be configured to match extremely non-planar surfaces or non-symmetrically placed grounds. Other options include: Tungsten probe tips; a high temperature version (40A-HT); and an integrated series or terminating resistor built into the signal tip. Many other types are available, please call.

For applications above 40 GHz, GGB Industries, Inc., offers the Model 50A, Model 67A, and Model 110A/H for DC to 110GHz applications.

Several models are available with wave guide inputs including the Model 50, Model 75, Model 90, Model 120, Model 140, and Model 220. The wave guide probes have an optional integral bias T for active device measurements.

Probing Expertise

GGB Industries, Inc., has broad capabilities in custom probe engineering and manufacturing and our staff is accustomed to creating unique solutions for the most difficult probing requirements. GGB Industries, Inc., is the leading supplier of high impedance active probes offering models with input capacitances of as low as .02 pF and frequency responses of up to 3.0 GHz.

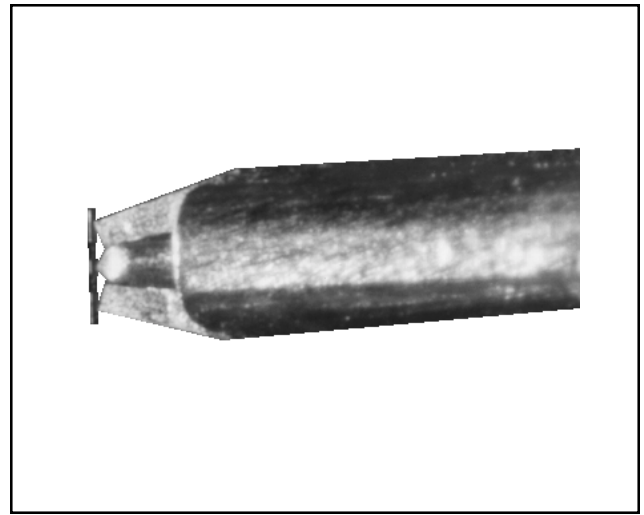

Closeup of Model 40A Tips with 150 Micron pitch almost touching a 50 Ω calibration load.

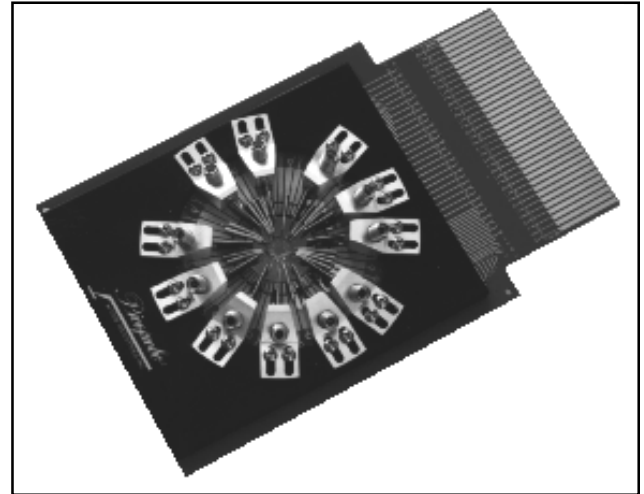

Typical Probe Card with Model 40A Probes

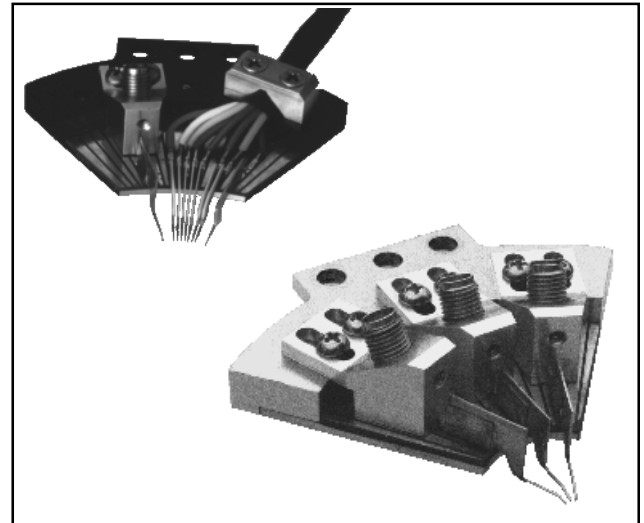

Examples of the Multi-Contact Wedge which combine Multiple RF and DC contacts .

Model 40A Performance Data¹ G,S,G Configuration

Frequency Range: DC to 40 GHz

Insertion Loss: Less than 1.0 db to 40 GHz
(.70 db typical)

Return Loss: Less than 30 db to 4 GHz
(35 db typical)
Less than 20 db to 26 GHz
(23 db typical)
Less than 18 db to 40 GHz
(20 db typical)

Crosstalk²: Less than 38 db to 40 GHz

¹ Specifications are for the P-style Model 40A Picoprobes with G,S,G configurations and pitches of between 50 and 300 microns. The C and T style Model 40A Picoprobes (see following page for mounting styles) have the same specifications except for insertion loss, which is less than 1.2 db (0.9 db typical).

² Crosstalk is measured using two probes contacting a bare sapphire substrate 100 microns apart.

Model 40A Performance Data³ G,S and S,G Configuration

Frequency Range: DC to 40 GHz

Insertion Loss: Less than 2.0 db to 40 GHz
(1.6 db typical)

Return Loss: Less than 30 db to 4 GHz
Less than 15 db to 26 GHz
Less than 12 db to 40 GHz

³ Specifications are for the P-style Model 40A Picoprobes

S_{11} Z
REF 1.0 Units
200.0mUnits/

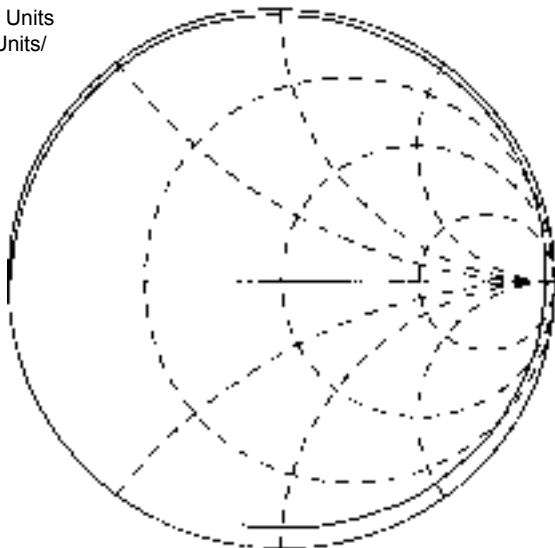

START 0.045000000 GHz
STOP 40.000000000 GHz

S11 FORWARD REFLECTION

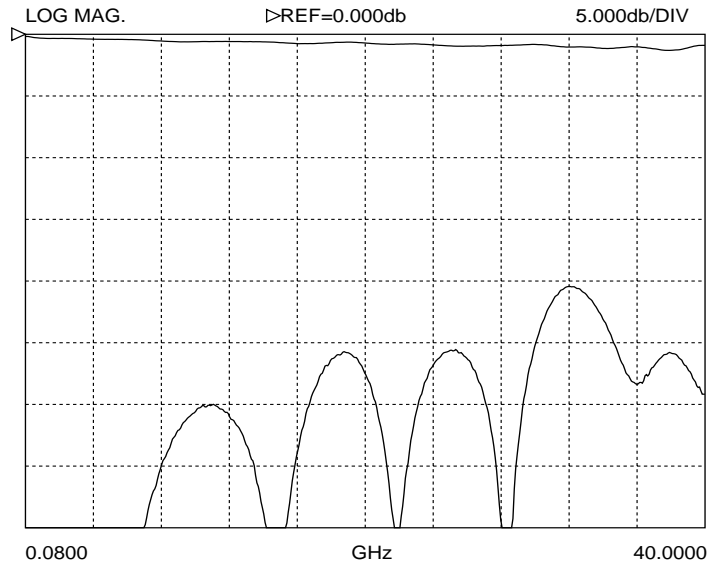

Typical uncalibrated performance of a Model 40A-GSG-150-P Picoprobe. The top trace is the round trip return loss into a short which is twice the probe's insertion loss. The bottom trace is the return loss into a 50 ohm load.

S12 FORWARD TRANSMISSION

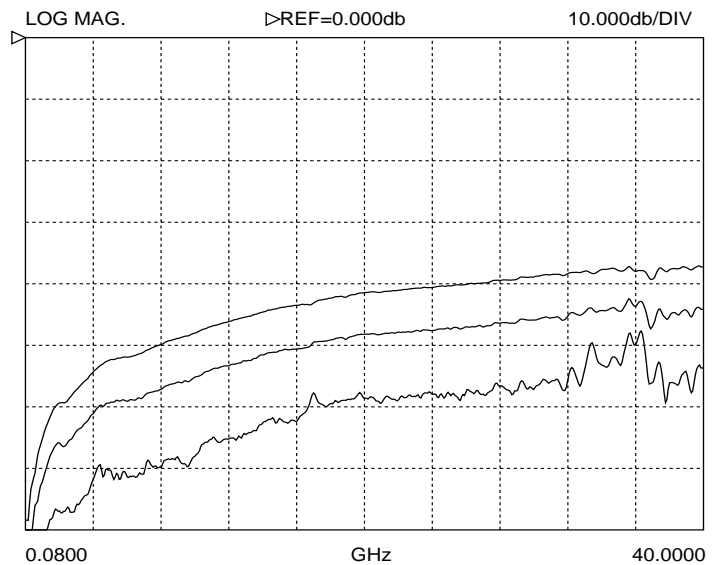

Crosstalk performance of two Model 40A-GSG-150-P Picoprobes while contacting a bare sapphire substrate with spacings of 100, 200, and 400 Microns.

LEFT: A Smith Chart showing the calibrated response of a Model 40A-GSG-150-P while contacting a coplanar offset short. The LRM method was used for calibration.

ORDERING INFORMATION

When ordering Model 40A probes, use the following part numbering convention:

Model 40A- _____ - ____ - _____
 configuration - pitch - mounting style

Configuration: Specify GSG, GS, or SG for tip placement where S is the signal tip and G is a ground tip. Use the following diagram to determine the appropriate configuration.

Top View

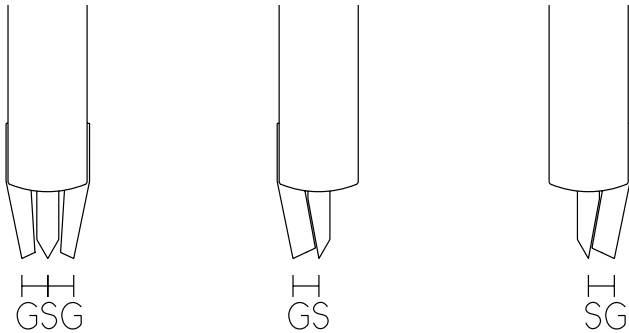

Pitch: Specify ground (G) to signal (S) tip spacing in Microns from 50 to 1250 microns. For standard GSG probes, the two spacings are equal. Contact the factory for spacings larger than 1250 microns or unusual tip placement and spacings.

Mounting Style: Choose from thirteen adapter styles. Seven of the most common adapter styles are pictured on the right. Specify T, C, GR, P, DP, EDP, LP, Q, F, S, DS, VP, or RVP. Choose the appropriate mounting type for your application. The P, DP, EDP, LP, Q, S, DS, VP, and RVP styles have the connector pointing back at a 45 degree angle to give more working area above the probe. The DP, EDP, DS, VP, and RVP styles are used where extra clearance beneath the probe is needed. When using DP, EDP, and DS style probes, probe positioning is more difficult due to the increased probing angle since the probe points slide further forward for a given change in the Z axis than our other style probes. Custom mounting styles are available.

Example: A 40A-GSG-150-P is a Model 40A with Ground, Signal, Ground configuration with 150 microns between each contact mounted in a P style adaptor.

Right: Specifications for seven of our most common adapter styles. Please contact our office or visit our web site at: www.picoprobe.com for information on other adapter styles.

Covered by US patent # 4,871,964

Mounting Styles and Dimensions

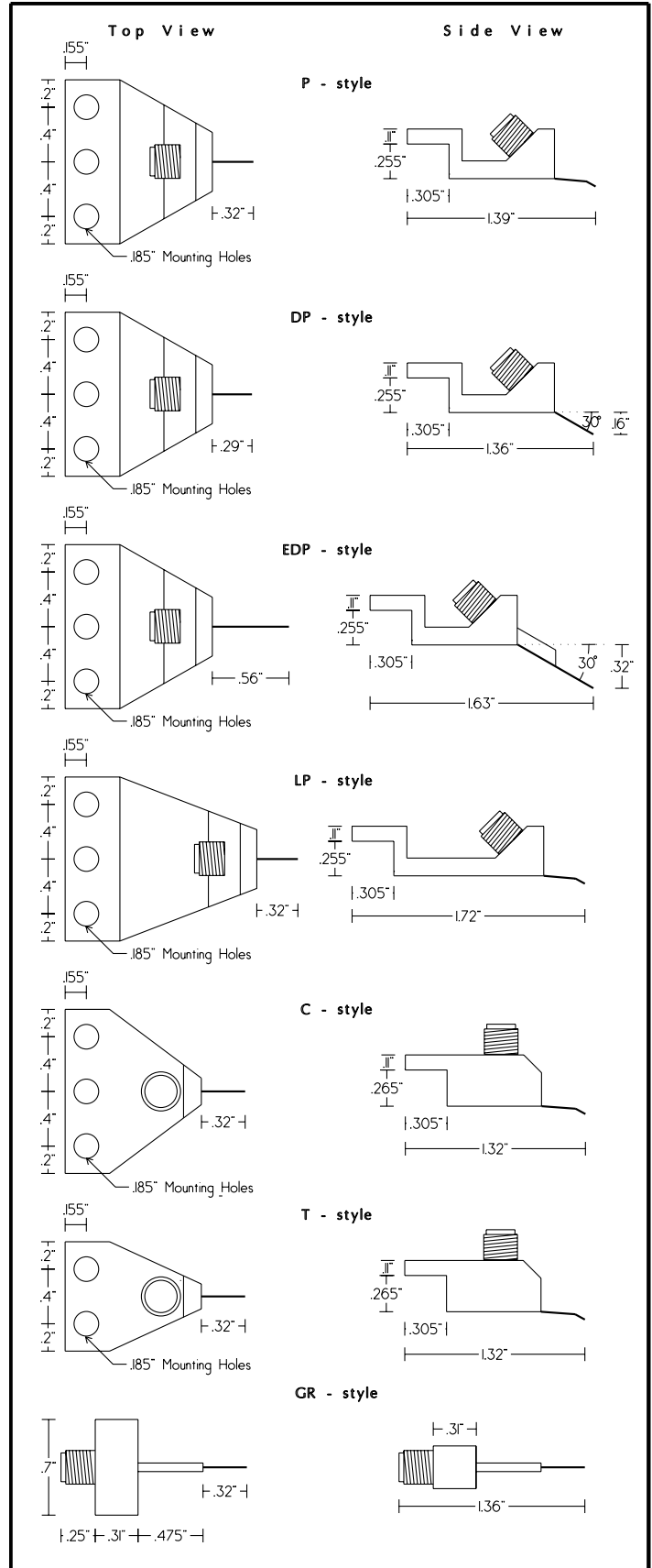

Picoprobe®

BY GGB INDUSTRIES INC.

Dual Model 40A Probes



Features

- Two probes on one positioner
- Probe to probe spacing user adjustable
- Same performance as regular Model 40A Picoprobe®

The Dual Model 40A consists of two separate probes mounted on a single holder. One probe is fixed to the holder; the other is adjustable. Each probe may be individually configured with GSG, GS, or SG footprints. The probe to probe spacing is user adjustable over a 4,000 micron (160 mil) range. When ordering, an initial setting, of up to 0.75 inches, should be specified. The spacing is measured as the distance between the signal contacts of each probe.

Enlarged photo of Dual Model 40A

ORDERING INFORMATION

To order a Dual Model 40A, use our regular Model 40A Picoprobe® literature as a guide to specify each probe individually. Then, the orientation of the two probes is specified from left to right looking from the top with the probe tips facing towards you. For example, a

40A-GS-150 /40A-GSG-150-D-300

is a dual probe. The left probe has a GS footprint with 150 microns between the ground and signal. The right probe has a GSG footprint with 150 microns between the grounds and signal. The spacing between the signal of the left probe and the signal of the right probe is 300 microns.

Covered by US patent # 4,871,964

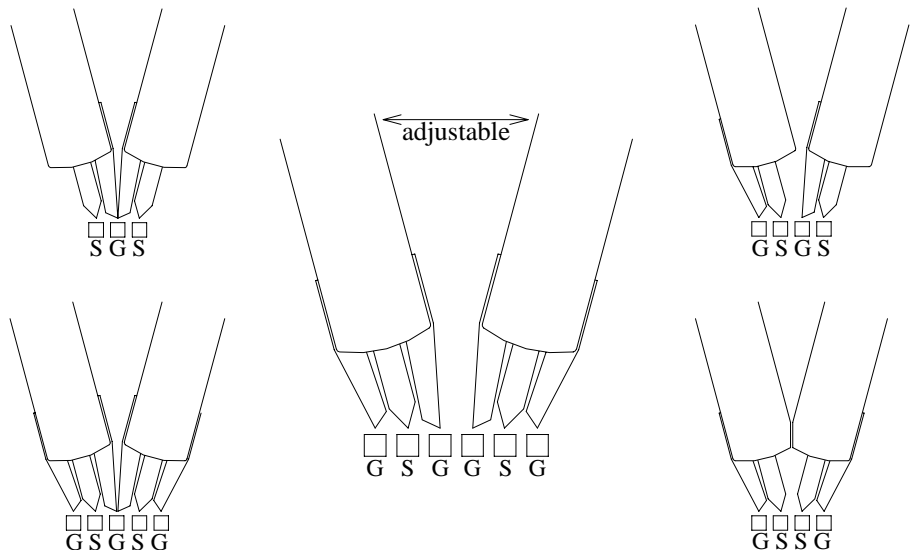

A few examples of probe point configurations



Dual Microwave Probes with frequencies up to 110GHz are available. Choose from either the Model 40A (2.9mm connector), Model 50A (2.4mm connector) Model 67A (1.85mm connector) or the Model 110H (1.0mm connector).

Covered by US patent # 4,871,964

**Even lower loss than
"the lowest loss probe in the industry"**

Picoprobe[®]

BY GGB INDUSTRIES INC.

Model 40M

High Performance Microwave Probes

Features of 40M-GSG-xxx-PLL



- **Durable**
- **DC to 40 GHz**
- **Insertion loss less than 0.5 db**
- **Return loss greater than 20db**
- **Measurement repeatability -52db**
- **Individually spring loaded contacts**
- **Variety of Footprints**
- **Patented coaxial design**

We have shaved another .25 db insertion loss off of our industry standard Model 40A Picoprobe[®]. This probe is recommended for certain types of load pull and noise parameter measurements when even our standard, super low, 0.75 db insertion loss (typical at 40 GHz) is too high.

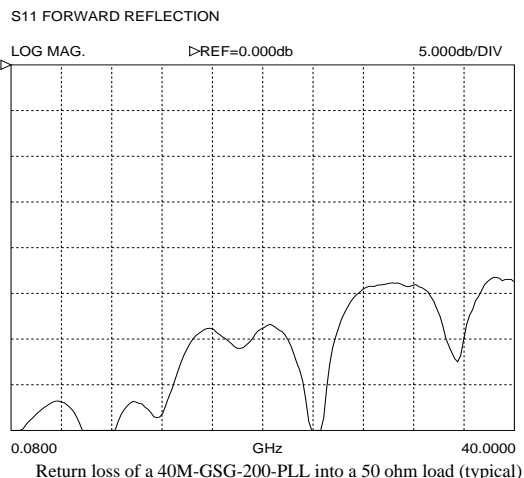
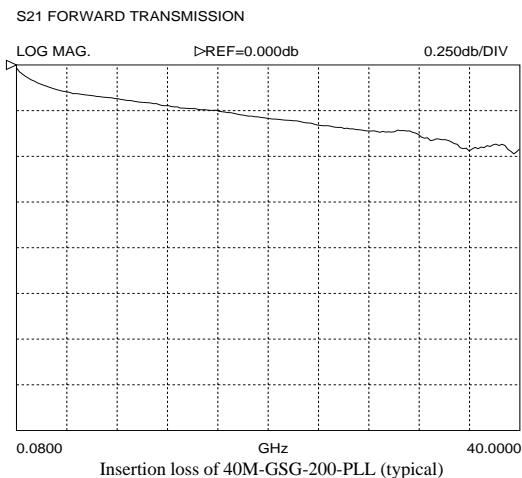

GGB INDUSTRIES, INC. • P.O. BOX 10958 • NAPLES, FL 34101
Telephone (239) 643-4400 • Fax (239-643-4403 • Email email@ggb.com www.picoprobe.com

Covered by US Patent #4,871,964



Model 50A

High Performance Microwave Probes

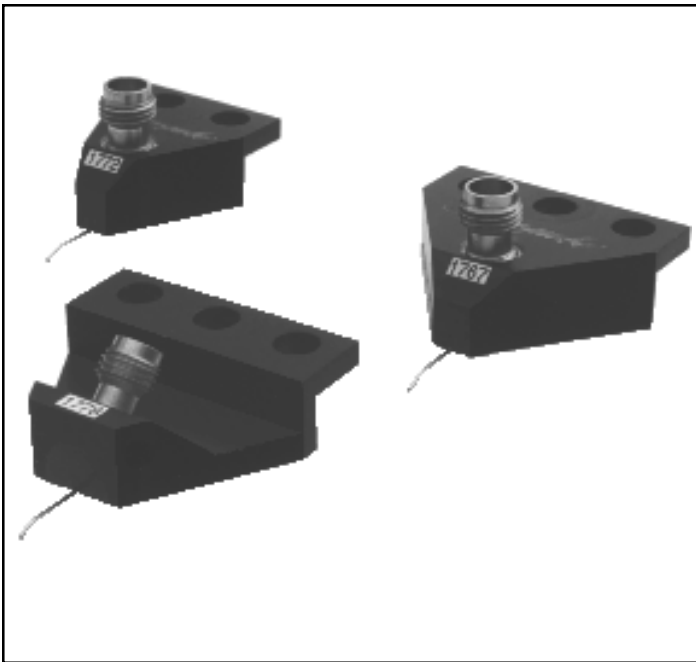

Model 50A probes mounted in three different adaptor styles

Features

- **Durable**
- **DC to 50 GHz**
- **Insertion loss less than 1.0 db**
- **Return loss greater than 18 db**
- **Measurement repeatability -50 db**
- **Individually spring loaded contacts**
- **Any pitch from 25 to 1250 microns**
- **Variety of Footprints**
- **Patented coaxial design**

The GGB Industries Model 50A probe sets new standards in microwave probing performance. Using low loss coaxial techniques, the Model 50A achieves an insertion loss of less than 1.0 db and a return loss of greater than 18 db through 50 GHz.

With its individually spring loaded, Beryllium-Copper tips, the Model 50A provides reliable contacts, even when probing

non-planar structures. This reliable low resistance contact is one of the keys to providing highly repeatable measurements. The Model 50 also provides direct viewing of the probe tips for accurate positioning.

The Model 50A can be mounted in various adaptors for use with standard microwave probe stations. Custom mounts are available.

Any pitch (tip spacing) from 50 to 1250 microns may be specified. The probe can be configured with Ground-Signal-Ground (G,S,G), Ground-Signal (G,S), or Signal-Ground (S,G) tip footprints. We recommend smaller pitches with a G,S,G footprint for best performance.

Connection to the Model 50A is through a female 2.4 mm connector and is also compatible with the V connector.

Flexible Tips for Flexible Probing

Each Model 50A has patented, independently spring loaded tips which make contact to the probing surface. Because the tips are flexible they minimize circuit damage, increase probe life, and most importantly, provide a reliable individually spring loaded contact for each point. With a small amount of overdrive, the point scrubs the surface to make a reliable contact free of dust, dirt, and oxide contamination. The ability to view the exact contact area eases probe positioning and allows for the precise positioning necessary for good LRM calibrations. The flexible tips even allow probing of non-planar surfaces such as ceramic substrates and laser diode structures.

Coaxial Transmission Improves Performance

The Model 50A uses a precision miniature 50 ohm coaxial cable from the probe tips to the connector interface. The coaxial design provides lower loss and less radiation than coplanar designs. The miniature coaxial cable is fabricated from flexible Beryllium-Copper which greatly improves the probe's durability.

Probe Cards

Model 40A probes can be mounted on standard 4.5 inch probe cards to provide a convenient method for testing wafers at high frequencies using standard automatic or manual probe stations. Picoprobe Cards combine our Model 40A probes for RF connections with DC needles for power and low frequency signals.

Line of Microwave Probes

Other models of Microwave probes are available with standard tip spacings of up to 1250 microns. Larger spacings are possible. For special applications, the Model 50A can be mounted in custom adaptors, the coaxial line can be bent to fit tight spaces, and the tips can be configured to match extremely non-planar surfaces or non-symmetrically placed grounds.

For applications in the 75 to 120 GHz range the Model 120 Picoprobe with a W band wave guide connection is available.

For applications below 40 GHz, GGB Industries offers the Model 40A Picoprobe which uses the 2.95mm K connector. The Model 40A performs up to 40 GHz with less than 1.0 db (0.7 db typical) insertion loss and return loss of greater than 18 db.

Probing Expertise

GGB Industries is the leading supplier of high impedance active probes offering models with input capacitances of as low as .02 pF and frequency responses of up to 3.0 GHz. With 22 years of probing experience, GGB Industries has broad capabilities in custom probe engineering.

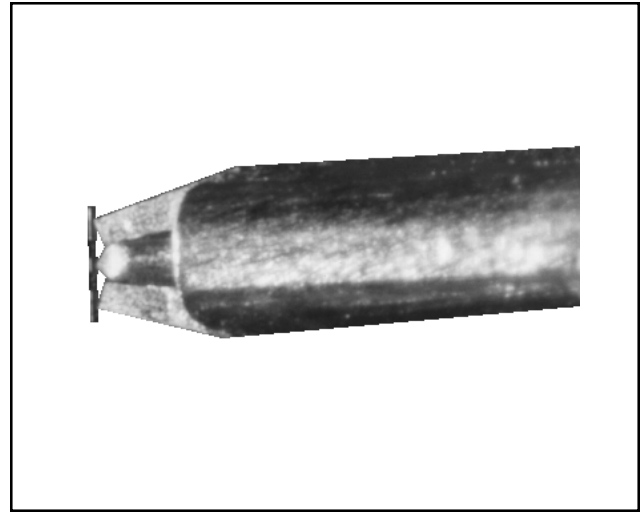

Closeup of Model 50A Tips with 150 Micron Pitch almost touching a 50 Ω calibration load.

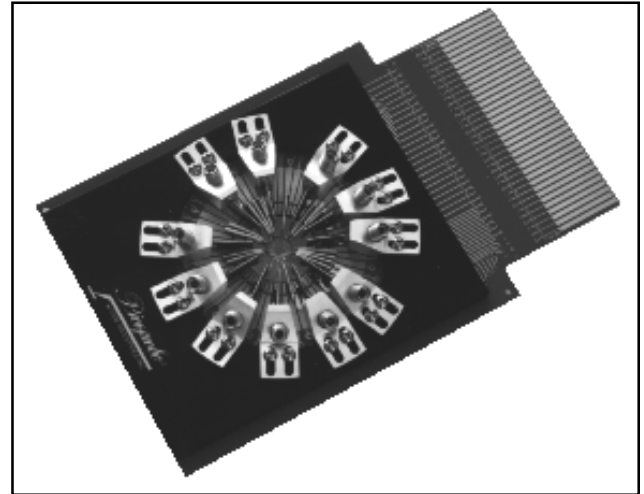

Typical Probe Card with Model 40A Probes

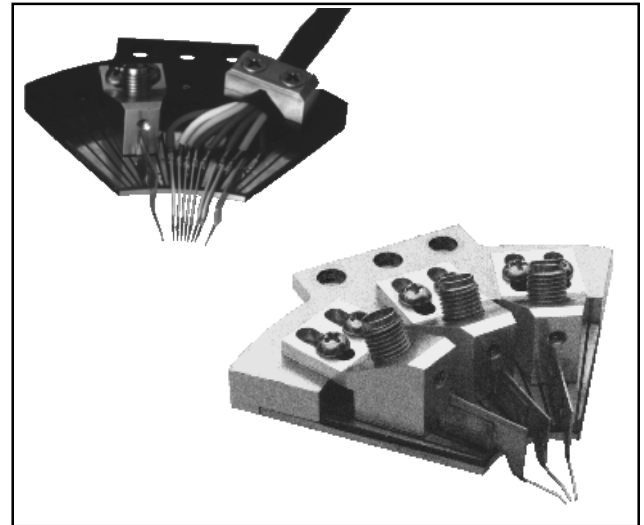

Examples of the Multi-Contact Wedge which combines Multiple RF and DC contacts.

Model 50A Performance Data¹ G,S,G Configuration

Frequency Range: DC to 50 GHz

Insertion Loss: Less than 1.0 db to 50 GHz
(.85 db typical)

Return Loss: Less than 30 db to 4 GHz
(35 db typical)
Less than 20 db to 26 GHz
(23 db typical)
Less than 18 db to 50 GHz
(20 db typical)

Crosstalk²: Less than 35 db to 50 GHz

¹ Specifications are for the P-style Model 50A Picoprobes with G,S,G configurations and pitches of between 50 and 250 microns. The C and T style Model 50A Picoprobes (see following page for mounting styles) have the same specifications except for insertion loss, which is less than 2.0 db (1.8 db typical).

² Crosstalk is measured using two probes contacting a bare sapphire substrate 100 microns apart.

S11 FORWARD REFLECTION

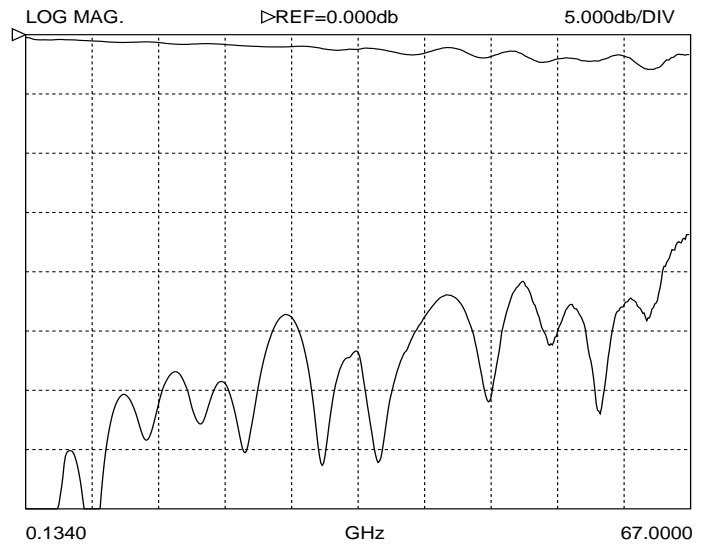

Typical uncalibrated performance of a Model 50A-GSG-150-P Picoprobe. The top trace is the round trip return loss into a short which is twice the probe's insertion loss. The bottom trace is the return loss into a 50 ohm load.

Model 50A Performance Data³ G,S and S,G Configuration

Frequency Range: DC to 50 GHz

Insertion Loss: Less than 2.0 db to 40 GHz
(1.6 db typical)

Return Loss: Less than 30 db to 4 GHz
Less than 15 db to 26 GHz
Less than 12 db to 40 GHz

³ Specifications are for the P-style Model 50A Picoprobes

S12 REVERSE TRANSMISSION

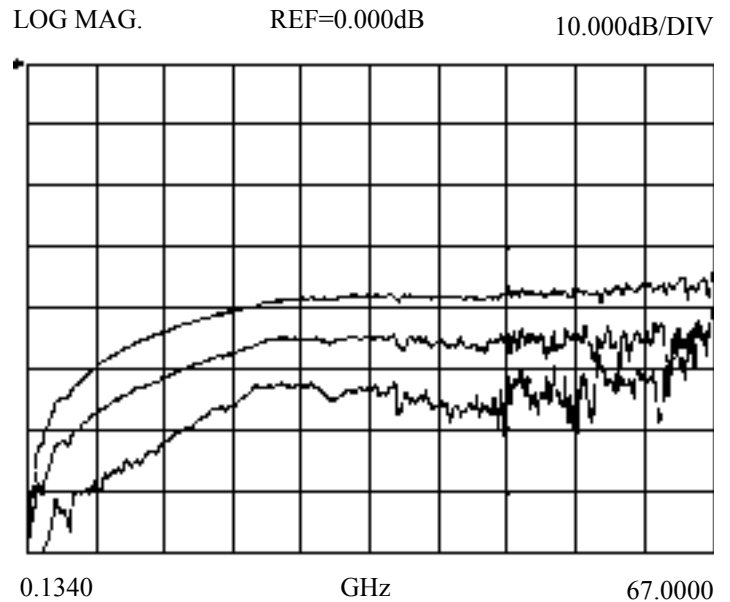

Crosstalk performance of two Model 50A-GSG-150-P Picoprobes while contacting a bare sapphire substrate with spacings of 100, 200, and 400 Microns.

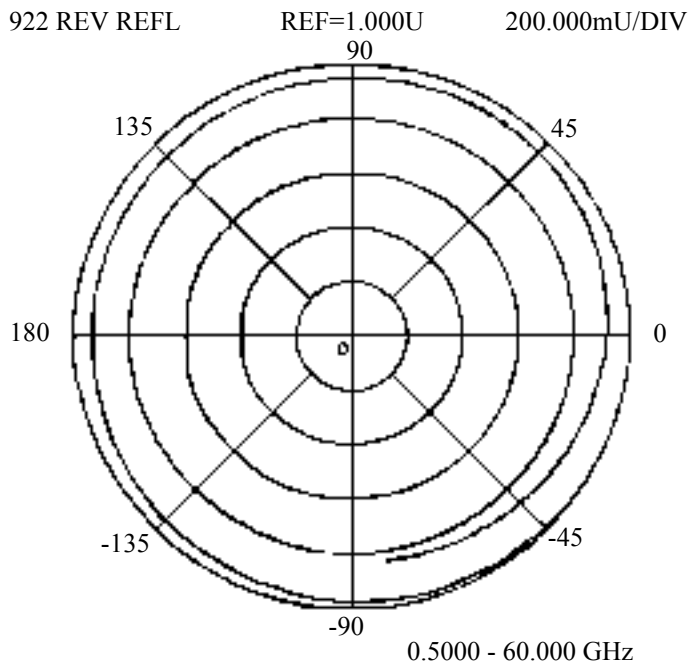

LEFT: A linear-polar chart showing the calibrated response of a Model 50A-GSG-150-P while contacting a 10 pSec coplanar line. The LOST method was used for calibration.

ORDERING INFORMATION

When ordering Model 50A probes, use the following part numbering convention:

Model 50A- _____ - ____ - _____
 configuration - pitch - mounting style

Configuration: Specify GSG, GS or SG for tip placement where S is the signal tip and G is a ground tip. Use the following diagram to determine the appropriate configuration.

Top View

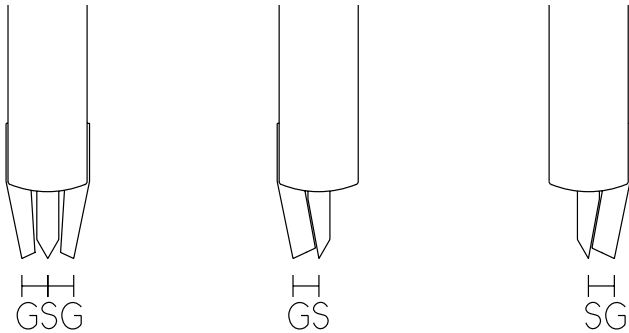

Pitch: Specify ground (G) to signal (S) tip spacing in Microns from 25 to 1250 microns. For standard GSG probes, the two spacings are equal. Contact the factory for spacings larger than 625 microns or unusual tip placement and spacings.

Mounting Style: Specify T,C,P, or DP. Choose the appropriate mounting type for your application. The P and DP styles have the connector pointing back at a 45 degree angle to give more working area above the probe. The DP style is used where extra clearance beneath the probe is needed, however probe positioning is more difficult. Due to the increased probing angle, the probe points slide further forward for a given change in the Z axis than our other style probes. Custom mounting styles are available.

Example: A 50A-GSG-150-P is a Model 50A with Ground, Signal, Ground configuration with 150 microns between each contact mounted in a P style adaptor.

Covered by US patent # 4,871,964

Mounting Styles and Dimensions

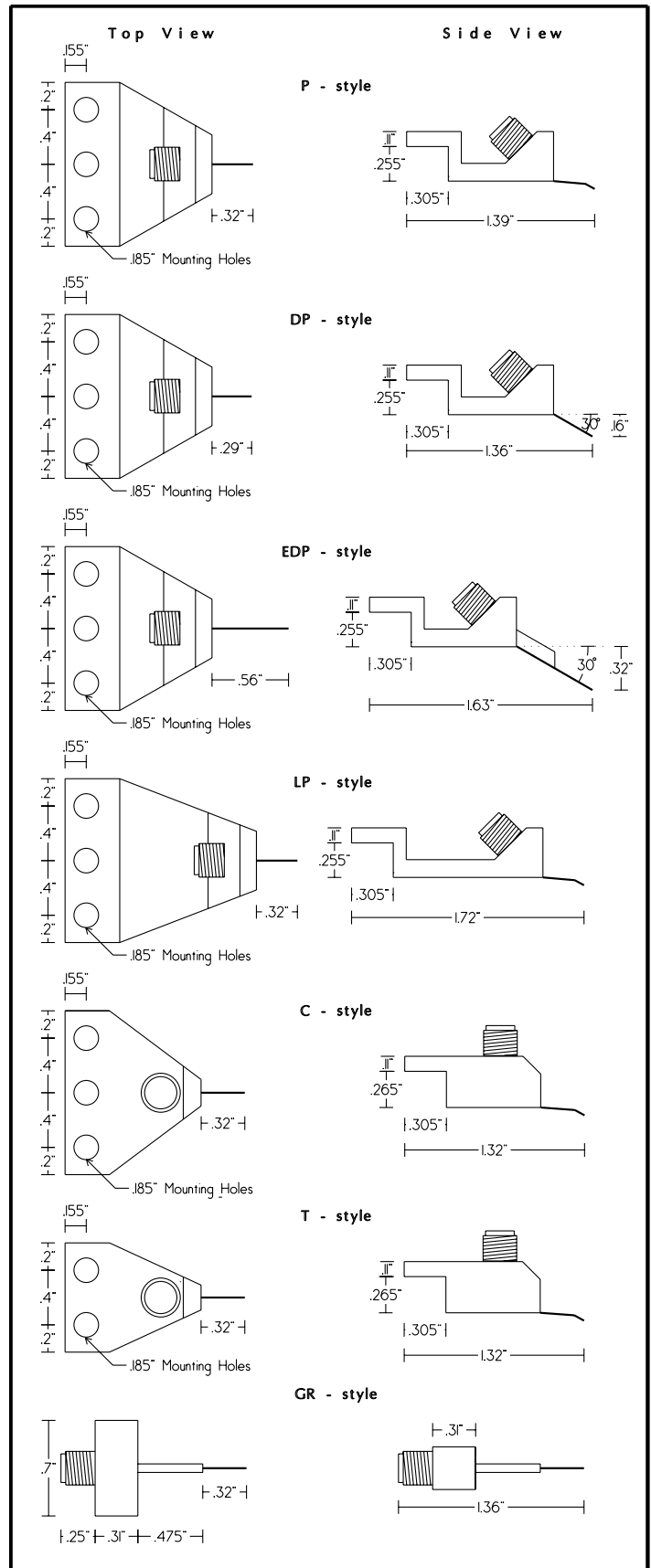

Picoprobe®

BY GGB INDUSTRIES INC.

Model 67A

High Performance Microwave Probes

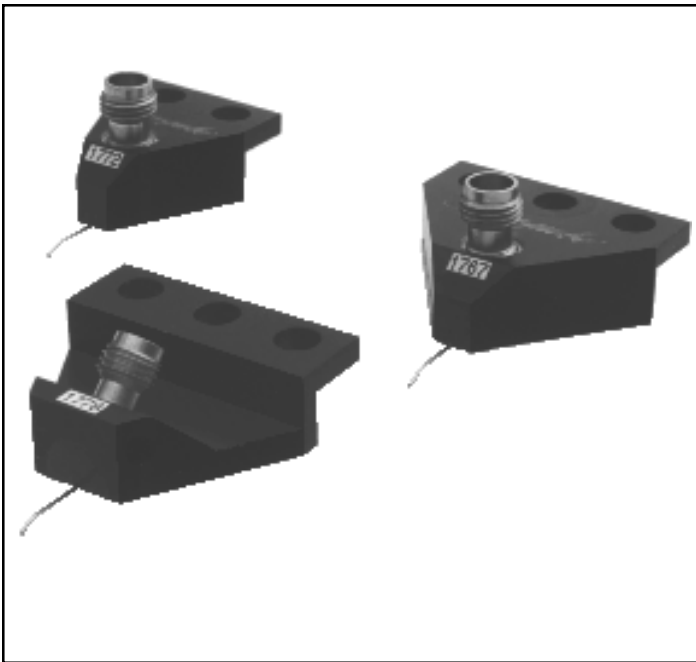

Model 67A probes mounted in three different adaptor styles

Features

- **Durable**
- **DC to 67 GHz**
- **Insertion loss less than 1.1 db**
- **Return loss greater than 14 db**
- **Measurement repeatability -50 db**
- **Individually spring loaded contacts**
- **BeCu or Tungsten tips available**
- **Any pitch from 50 to 1250 microns**
- **Variety of Footprints**
- **Patented coaxial design**

The GGB Industries Model 67A probe sets new standards in microwave probing performance. Using low loss coaxial techniques, the Model 67A achieves an insertion loss of less than 1.1 db and a return loss of greater than 14 db through 67 GHz

With its individually spring loaded, Beryllium-Copper tips, the Model 67A provides reliable contacts, even when probing

non-planar structures. This reliable low resistance contact is one of the keys to providing highly repeatable measurements. The Model 67A also provides direct viewing of the probe tips for accurate positioning.

The Model 67A can be mounted in various adaptors for use with standard microwave probe stations. Custom mounts are available.

Any pitch (tip spacing) from 50 to 1250 microns may be specified. The probe can be configured with Ground-Signal-Ground (G,S,G), Ground-Signal (G,S), or Signal-Ground (S,G) tip footprints. We recommend smaller pitches with a G,S,G footprint for best performance.

Connection to the Model 67A is through a female 1.85 mm V connector. (2.4 mm compatible)

Flexible Tips for Flexible Probing

Each Model 67A has patented, independently spring loaded tips which make contact to the probing surface. Because the tips are flexible they minimize circuit damage, increase probe life, and most importantly, provide a reliable individually spring loaded contact for each point. With a small amount of overdrive, the point scrubs the surface to make a reliable contact free of dust, dirt, and oxide contamination. The ability to view the exact contact area eases probe positioning and allows for the precise positioning necessary for good LRM calibrations. The flexible tips even allow probing of non-planar surfaces such as ceramic substrates and laser diode structures.

Coaxial Transmission Improves Performance

The Model 67A uses a precision miniature 50 ohm coaxial cable from the probe tips to the connector interface. The coaxial design provides lower loss and less radiation than coplanar designs. The miniature coaxial cable is fabricated from flexible Beryllium-Copper which greatly improves the probe's durability.

Probe Cards

Model 40A probes can be mounted on standard 4.5 inch probe cards to provide a convenient method for testing wafers at high frequencies using standard automatic or manual probe stations. Picoprobe Cards combine our Model 40A probes for RF connections with DC needles for power and low frequency signals.

Line of Microwave Probes

Other models of Microwave probes are available with standard tip spacings of up to 1250 microns. Larger spacings are possible. For special applications, the Model 67A can be mounted in custom adaptors, the coaxial line can be bent to fit tight spaces, and the tips can be configured to match extremely non-planar surfaces or non-symmetrically placed grounds.

Three models are available with wave guide inputs. WR-22 for 33 to 50 GHz, WR-15 for 50 to 75 GHz, and WR-10 for 75 to 110 GHz. The wave guide probes have an integral bias T for active device measurements.

For applications below 40 GHz, GGB Industries offers the Model 40A Picoprobe which uses the 2.95mm K connector. The Model 40A performs up to 40 GHz with less than 1.0 db (0.7 db typical) insertion loss and return loss of greater than 18 db.

Many other types are available, please call.

Probing Expertise

GGB Industries is the leading supplier of high impedance active probes offering models with input capacitances of as low as .02 pF and frequency responses of up to 3.0 GHz. With 22 years of probing experience, GGB Industries has broad capabilities in custom probe engineering.

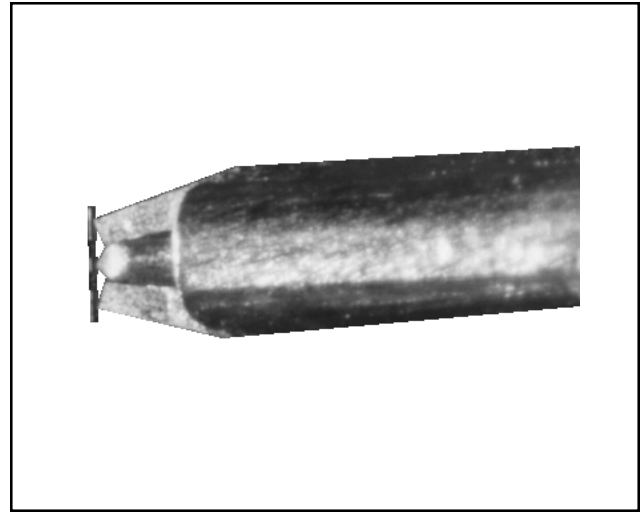

Closeup of Model 67A Tips with 150 Micron Pitch almost touching a 50 Ω calibration load.

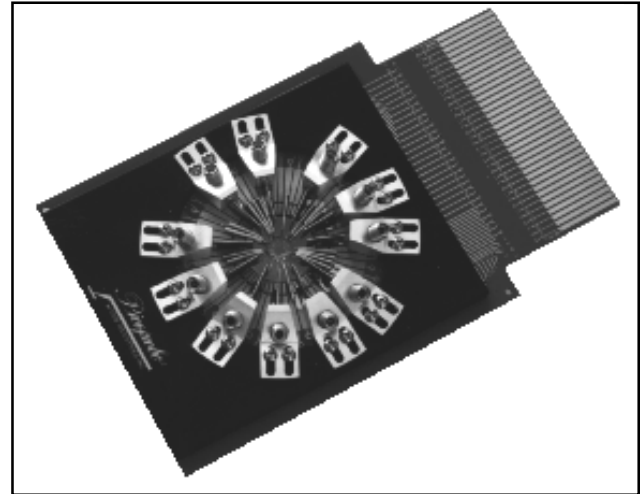

Typical Probe Card with Model 40A Probes

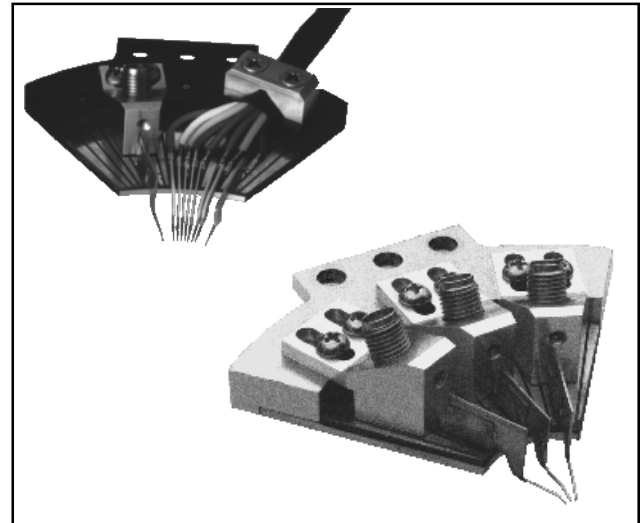

Examples of the Multi-Contact Wedge which combine Multiple RF and DC contacts .

Model 67A Performance Data¹ G,S,G Configuration

Frequency Range:	DC to 67 GHz
Insertion Loss:	Less than 1.1 db to 67 GHz (.95 db typical)
Return Loss:	Less than 35 db to 4 GHz (35 db typical) Less than 20 db to 26 GHz (23 db typical) Less than 18 db to 40 GHz (20 db typical) Less than 14 db to 67 GHz (16 db typical)
Crosstalk²:	Less than 35 db to 67 GHz

¹ Specifications are for the P-style Model 67A Picoprobes with G,S,G configurations and pitches of between 50 and 250 microns. The C and T style Model 67A Picoprobes (see following page for mounting styles) have the same specifications except for insertion loss, which is less than 1.3 db (1.2 db typical).

² Crosstalk is measured using two probes contacting a bare sapphire substrate 100 microns apart.

Model 67A Performance Data³ G,S and S,G Configuration

Frequency Range:	DC to 67 GHz
Insertion Loss:	Less than 1.0 db to 40 GHz (0.9 db typical)
Return Loss:	Less than 30 db to 4 GHz Less than 15 db to 26 GHz Less than 12 db to 40 GHz

³ Specifications are for the P-style Model 67A Picoprobes

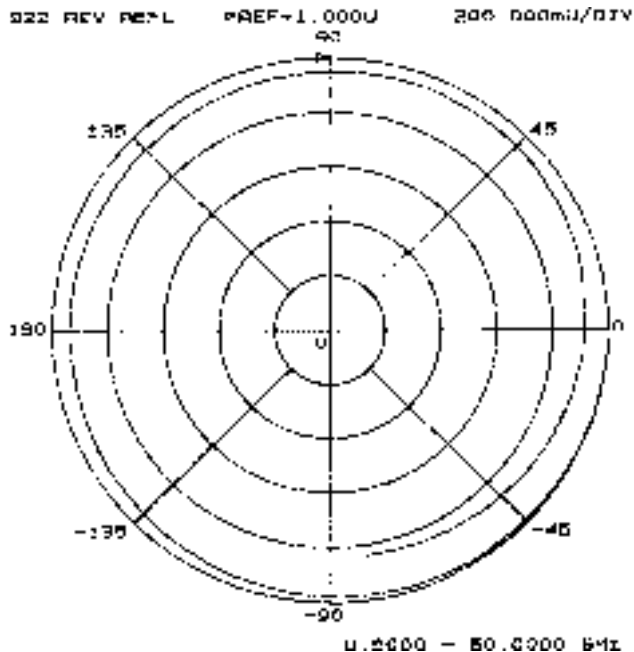

S11 FORWARD REFLECTION

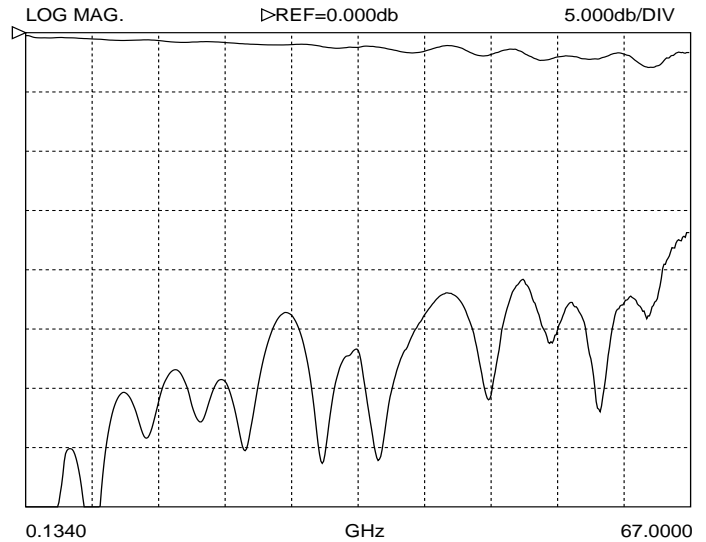

Typical uncalibrated performance of a Model 67A-GSG-150-P Picoprobe. The top trace is the round trip return loss into a short which is twice the probe's insertion loss. The bottom trace is the return loss into a 50 ohm load.

S12 REVERSE TRANSMISSION

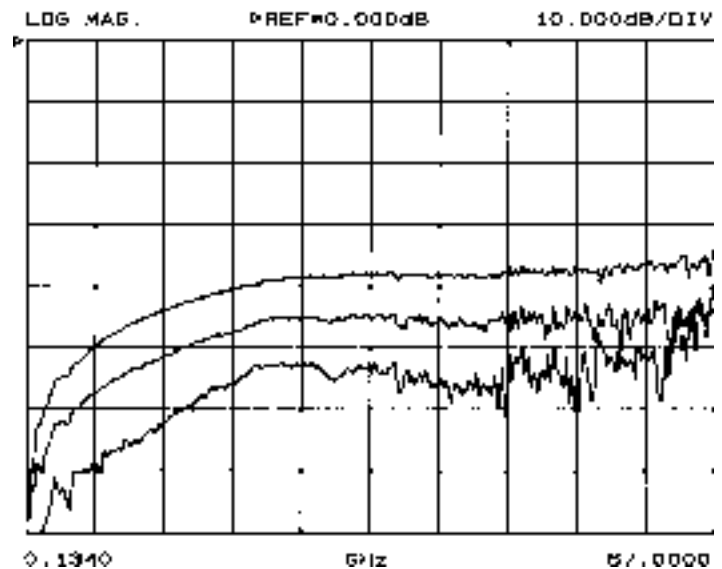

Crosstalk performance of two Model 67A-GSG-150-P Picoprobes while contacting a bare sapphire substrate with spacings of 100, 200, and 400 Microns.

LEFT: A linear-polar chart showing the calibrated response of a Model 67A-GSG-150-P while contacting a 10 pSec coplanar line. The LOST method was used for calibration.

ORDERING INFORMATION

When ordering Model 67A probes, use the following part numbering convention:

Model 67A- _____ - ____ - _____
 configuration - pitch - mounting style

Configuration: Specify GSG, GS or SG for tip placement where S is the signal tip and G is a ground tip. Use the following diagram to determine the appropriate configuration.

Top View

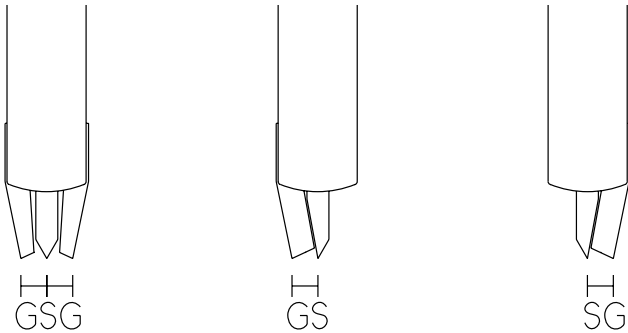

Pitch: Specify ground (G) to signal (S) tip spacing in Microns from 50 to 1250 microns. For standard GSG probes, the two spacings are equal. Contact the factory for spacings larger than 1250 microns or unusual tip placement and spacings.

Mounting Style: Specify T,C,GR,P,DP,EDP or LP. Choose the appropriate mounting type for your application. The P,DP,EDP and LP styles have the connector pointing back at a 45 degree angle to give more working area above the probe. The DP and EDP styles are used where extra clearance beneath the probe is needed. However, probe positioning is more difficult. Due to the increased probing angle, the probe points slide further forward for a given change in the Z axis than our other style probes. Custom mounting styles are available.

Example: A 67A-GSG-150-P is a Model 67A with Ground, Signal, Ground configuration with 150 microns between each contact mounted in a P style adaptor.

Covered by US patent # 4,871,964

Mounting Styles and Dimensions

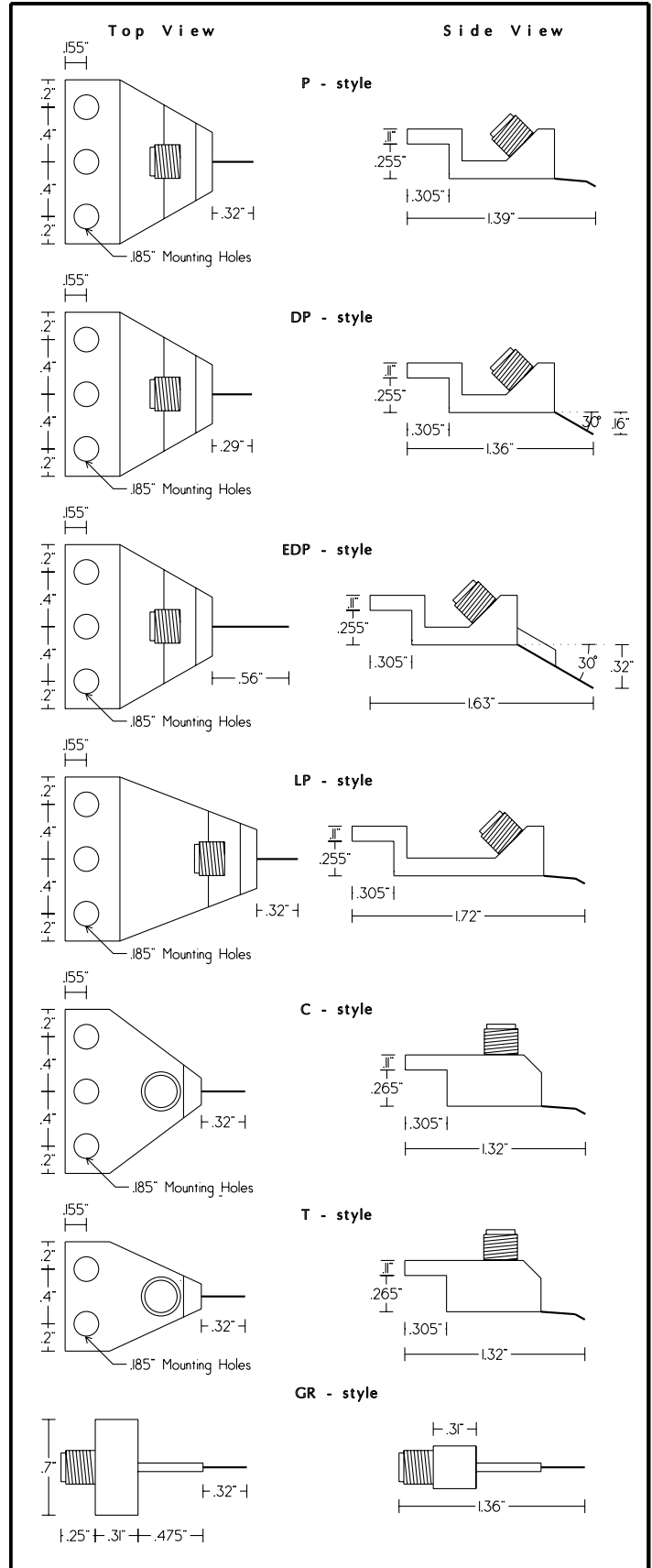

Picoprobe®

BY GGB INDUSTRIES INC.

Model 110H High Performance Microwave Probes



Model 110H Picoprobe® with female 1.0 mm connector

Features

- **Durable**
- **DC to 110 GHz**
- **Insertion loss 1.5 dB max.**
- **Return loss 15 dB max.**
- **Individually spring loaded contacts**
- **Measurement repeatability -80 dB**
- **Patented coaxial design**
- **Available with a 1.0 mm connector**

The Model 110H Picoprobe which incorporates our patented coaxial design techniques, has inherent low loss and low dispersion characteristics. Through its unique design, the Model 110H Picoprobe achieves an insertion loss of less than 1.5 dB and a return loss of greater than 15 dB over its frequency range.

With individually spring loaded, Beryllium-Copper tips, the Model 110H provide reliable contacts, even when probing

non-planar structures. This reliable low resistance contact is one of the keys to providing highly repeatable measurements at W band frequencies.

Like all of our Picoprobes, the Model 110H allow direct viewing of the probe tips for accurate positioning.

Any pitch (tip spacing) from 50 to 1250 microns may be specified. The probe can be configured with Ground-Signal-Ground

(G,S,G), Ground-Signal (G,S), or Signal-Ground (S,G) tip footprints. We recommend smaller pitches with a G,S,G footprint for best performance.

The Model 110H utilizes a female 1.0mm connector.

